



# Installation Instructions

Phone, Navigation Systems

B84 03 03

Page 1 of

June 2003

Product  
Development

## ***SUBJECT***

## **BMW Universal Bluetooth™ Hands-Free-Kit**

## ***MODEL***

E46 - Sedan/Sport Wagon as of 3/02

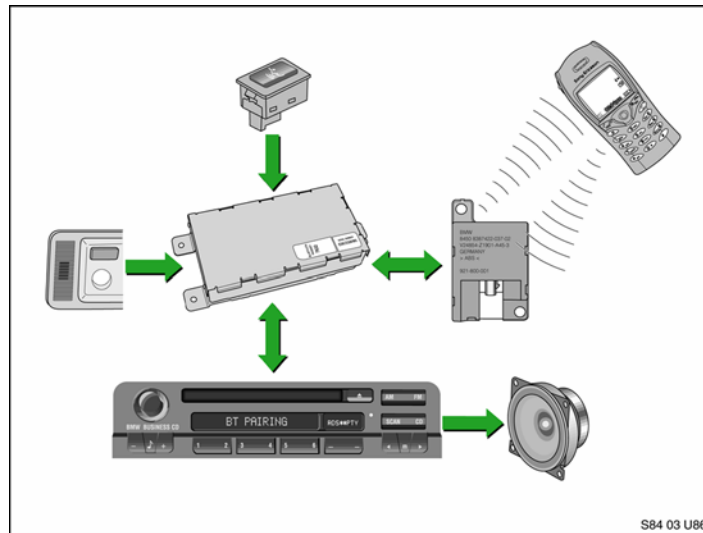

"Never use any electronic device or make any inputs while driving that may distract you from driving safely.

Pay attention to traffic laws and road conditions/situations. Safe vehicle operation is the driver's responsibility. Always wear your safety belt."

## ***INSTALLATION TIME***

The installation time for this kit is approximately 1.25 hour

These instructions were developed especially for BMW vehicles and are not to be compared to any existing instructions for vehicles other than BMW. No methods other than those specified in this document are to be used to install the **BMW Universal Bluetooth™ Hands-Free Kit**

Please initial and route to the following for information before filing										
<input checked="" type="checkbox"/>	Service Manager		<input checked="" type="checkbox"/>	Warranty		<input checked="" type="checkbox"/>	Service Technicians - Initial Below			
<input checked="" type="checkbox"/>	Service Advisor			Parts Mgr.						
<input checked="" type="checkbox"/>	Service Advisor			Body Shop						
<input checked="" type="checkbox"/>	Shop Foreman			PDI Dept.						

★ ★ **FIX IT RIGHT THE FIRST TIME, ON TIME, EVERY TIME** ★ ★



**PARTS INFORMATION:**

Description	Qty	BMW Part Number
ULF Control Module	1	84 21 6 934 552
Voice Input System Jumper Plug	1	84 11 0 018 038
ULF Control Module Mounting Bracket (Touring)	1	84 13 6 924 698
E46 Sedan/Coupe/Touring Installation Kit	1	84 11 0 302 639

**Installation Kit Contents:**

M5 Bolt w/washer	6	07 11 9 902 932
M5 Hex Nut	6	63 21 1 371 401
M5 Clip Nut	4	61 13 1 372 033
Wire tie	2	61 13 1 367 599
ULF Control Module Mounting Bracket (if rear carrier brackets are installed)	1	84 13 6 924 553
Microphone	1	84 31 8 380 319
Bluetooth™ Antenna	1	84 50 6 928 461
Bluetooth™ Antenna Mounting Bracket	1	84 13 6 912 160
Pairing Button	1	84 13 0 302 715
Adapter Harness	1	84 11 0 302 181
ULF Pairing Button Cutout Template	1	84 11 0 304 482
ULF Owner's Manual	1	84 11 0 302 638
ULF Passkey Reference Card	1	84 11 0 302 646
ULF E46 Installation Instructions	1	84 11 0 302 643
Owner's Manual For Voice Input System	1	84 11 0 027 942

**PROCEDURE:****To install and connect the BMW Universal Bluetooth™ Hands-Free System**

Disconnect Battery prior to starting the installation.

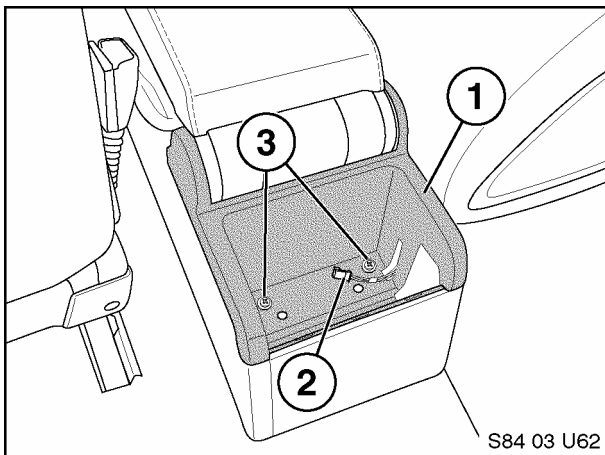
**A. Bluetooth™ Antenna & Pairing Button Installation**

1. Remove the rear ashtray and disconnect the illumination light (2).
2. Remove two Phillips screws (3) and remove the rear ashtray assembly (1).

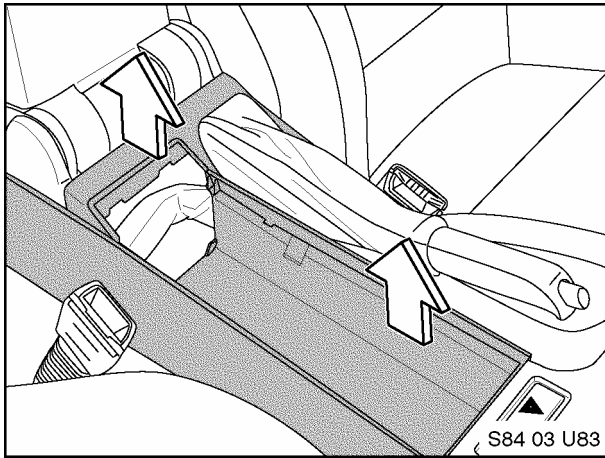

3. Remove the center console storage tray (2), refer to RA 51 16 200.

The center console will need to be removed in order to install the pairing button later in the procedure.

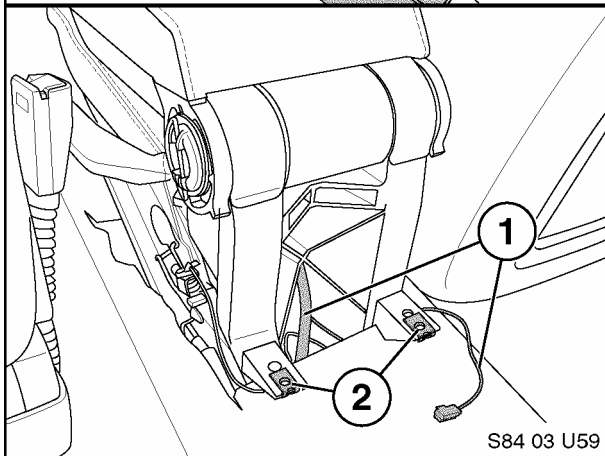

4. Locate the black FAKRA connector (1), located below the rear ashtray assembly.

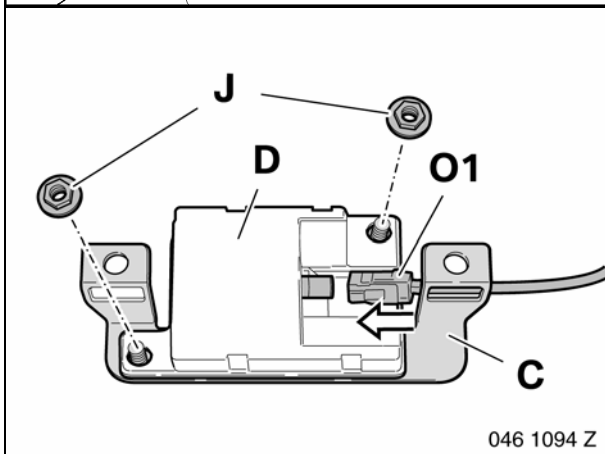

5. Secure the Bluetooth™ antenna (D), P/N 84 50 6 928 461, to the antenna-mounting bracket (C), P/N 84 13 6 912 160, using two M5 hex nuts (J), P/N 63 21 371 401.

6. Connect the black FAKRA connector (1) to the antenna (D).

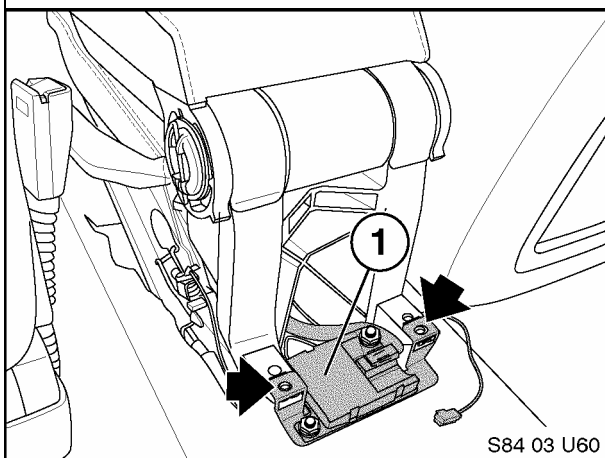

7. Place the mounting bracket with antenna (1) on top of the mounting points.

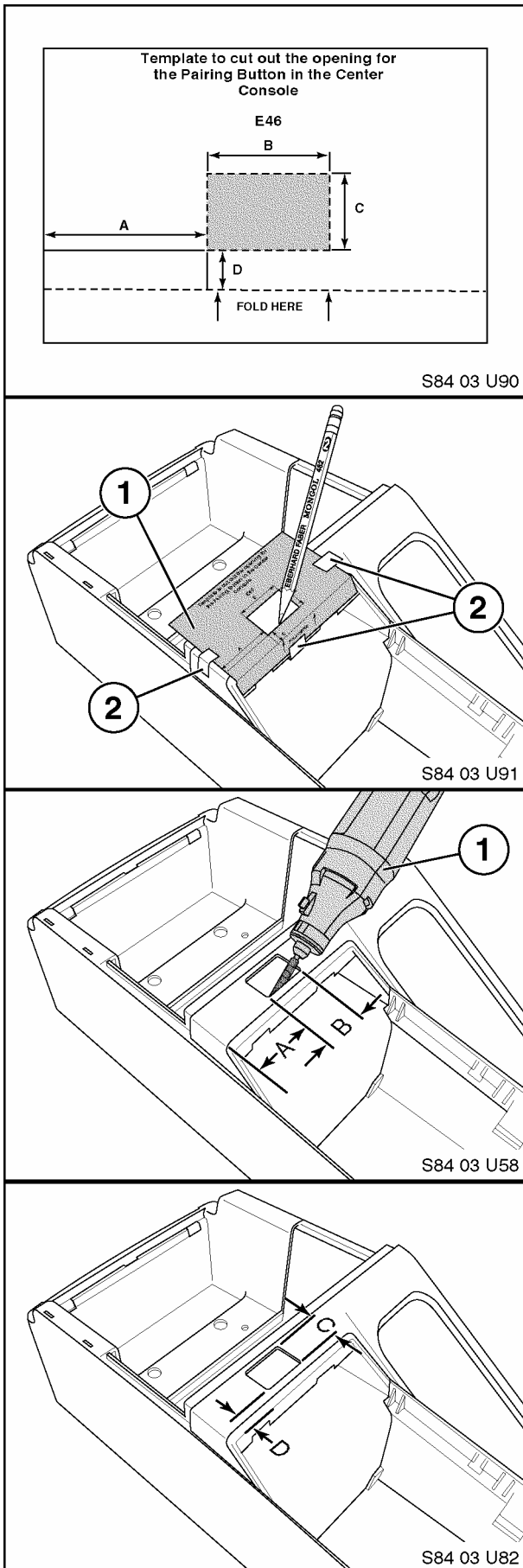

8. In order to install the Pairing Button, P/N 84 13 0 302 715, an opening must be cut into the rear of the center console. The area to be cut out can be marked using the template P/N 84 11 0 304 482

9. Cut out the template as indicated and fold one side of the template

10. Place the template (1) onto the center console.

11. Secure the template in place by taping the edges of the template to the console as shown (2).

12. Mark the area to be cut out using a pencil

13. The cut out can be made using a rotary cutting tool (1) with a high-speed cutting bit attachment.

14. Use the following measurements to properly center the switch opening if not using the template:

Measurement A = 33 mm (From inside corner/edge to locate the left side of the switch opening)

Measurement B = 25 mm (Establish the length of the opening)

15. Marking cut out continued:

Measurement D = 7 mm (From leading edge, to establish the forward edge of the switch opening).

Measurement C = 16 mm (Define the width of the switch opening).

16. Carefully cut out the marked rectangle. Use a small file to clean up the edges and enlarge the opening as necessary.

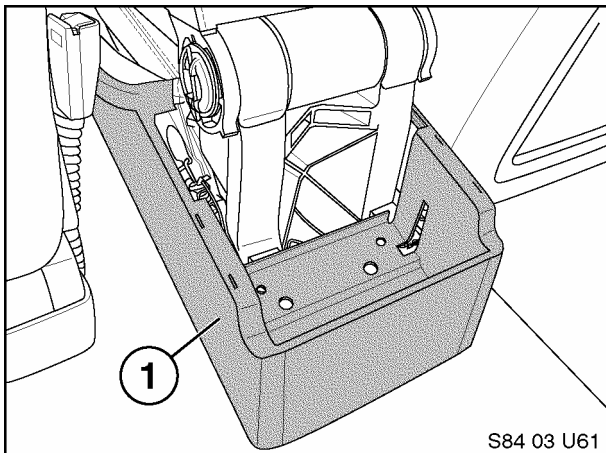

17. Carefully reinstall the center console.

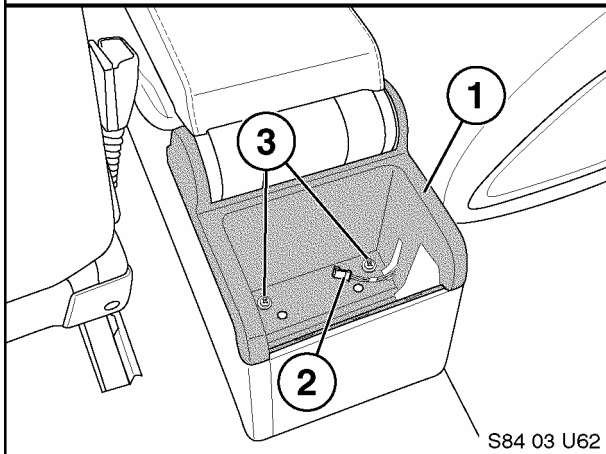

18. Reinstall the top panel (1) and reinstall the two Phillips head screws (3) making certain that they go all the way down through the antenna-mounting bracket to the clip nuts.

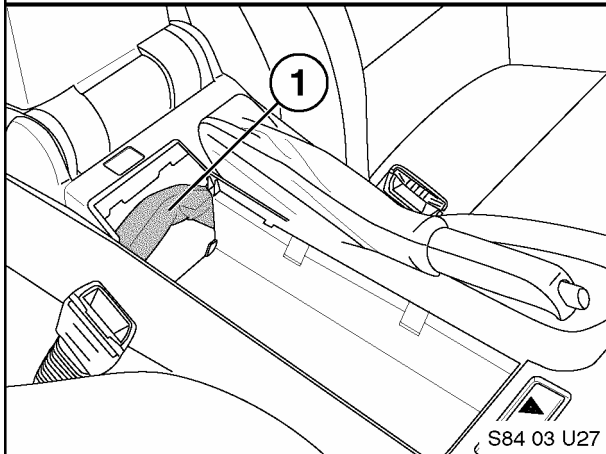

19. Locate the black 18-pin connector X4545 in bundle (1).

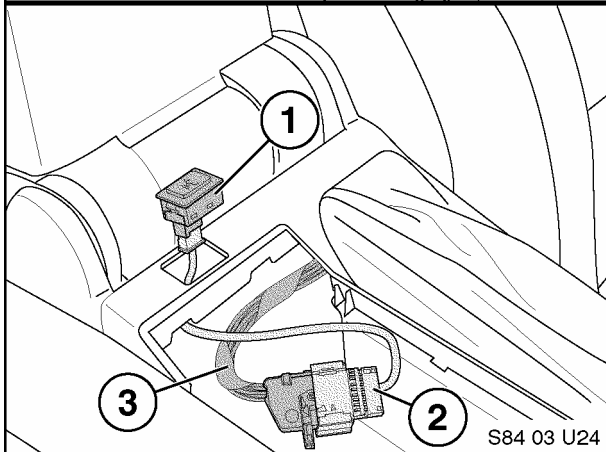

20. Connect the interface harness (2), P/N 84 11 0 302 181, to X4545 (3).

21. Route the end of the interface harness (2) with the white 3-pin connector through the cutout in the console.

22. Connect the pairing button (1), P/N 84 13 0 302 715, to the interface harness (2).

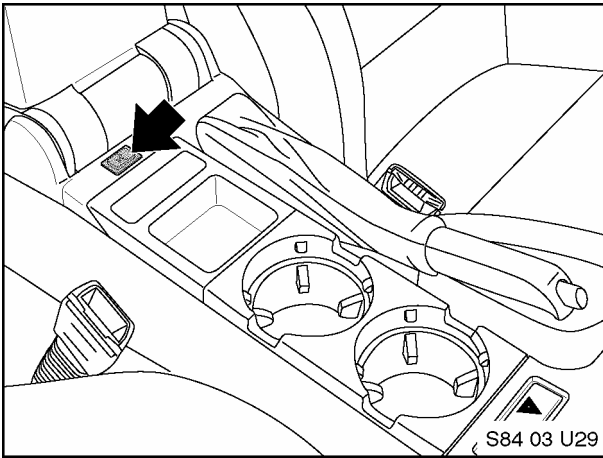

23. Insert the Pairing Button, P/N 84 13 0 302 715, into the cutout and reinstall the cupholders and coin tray.

## B. ULF Control Module Installation

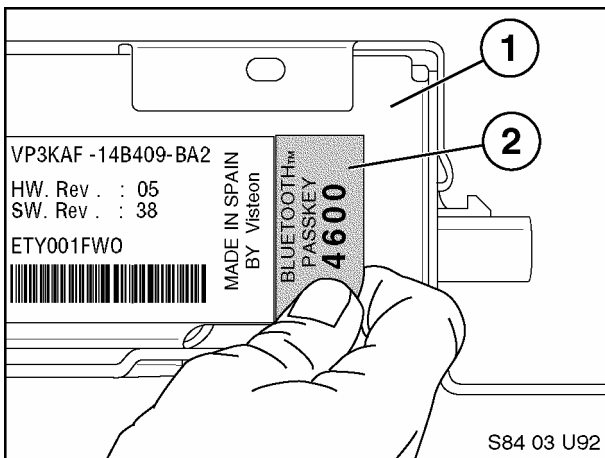

1. Remove/ peel off the Bluetooth™ Passkey sticker (2) from the label on the ULF Control Module (1).

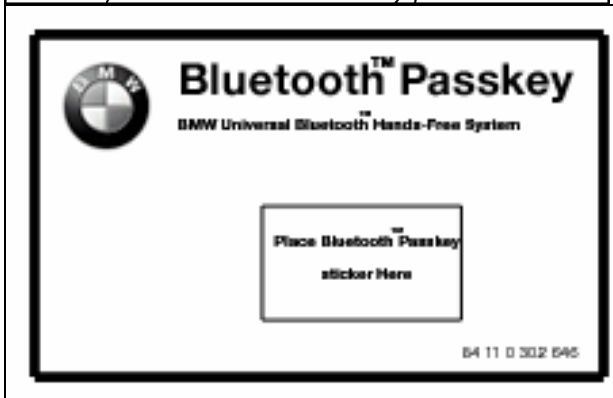

2. Place the Bluetooth™ Passkey sticker removed from the ULF Control Module onto the ULF Passkey Reference Card, P/N 84 11 0 302 638.
3. Place this card inside the owner's manual portfolio. Show this card to the customer when demonstrating the system and the pairing procedure to the customer. The code on the sticker is needed to pair phones to the ULF Control Module.

## E46 Touring

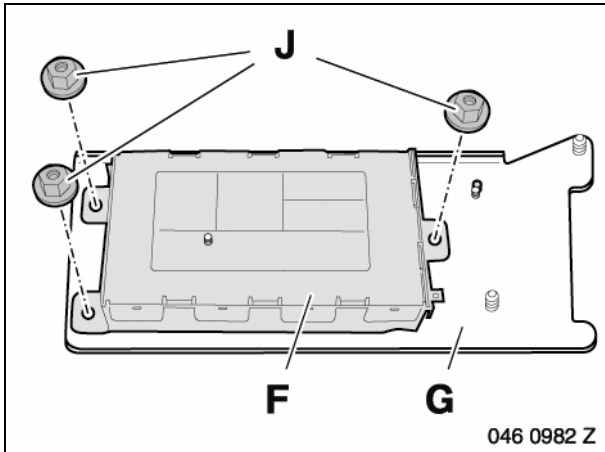

1. Attach the ULF Control Module (F) to the mounting bracket (G), P/N 84 13 6 924 698; use three M5 hex nuts (J), P/N 61 21 1 371 401.

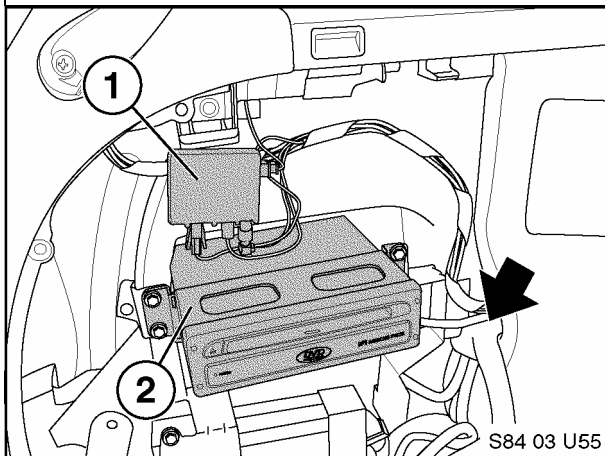

2. Locate the black 54-pin connector and white FAKRA connector, bundled near the left rear wheel hub.

NOTE: If a navigation unit (2) and/ or CD changer is installed it will need to be removed, in order to gain access to the inner portion of the left rear quarter panel.

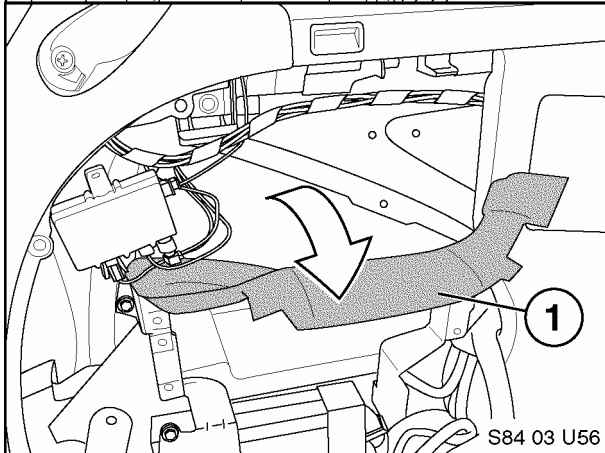

3. Carefully pull back on the felt panel (1) to gain access to the inner area of the rear quarter panel.

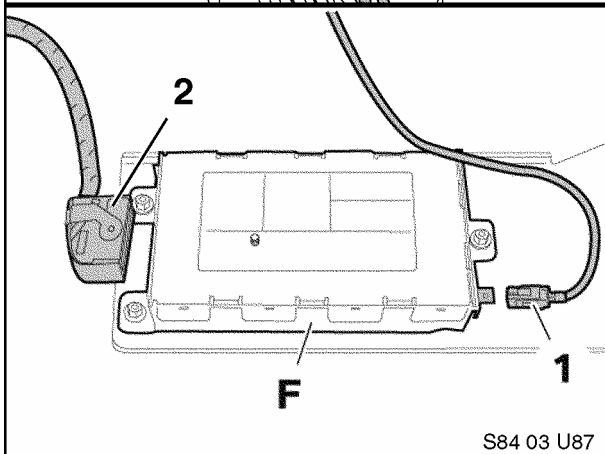
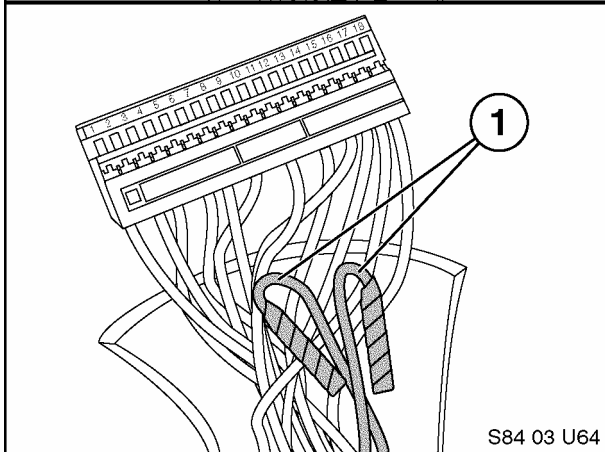
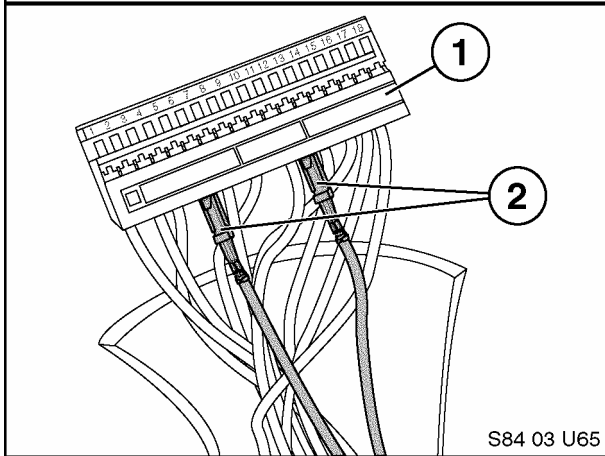
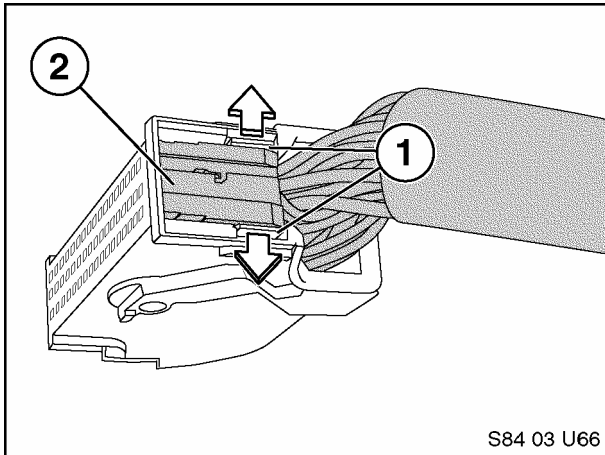

4. Prior to connecting the black 54-pin connector to the ULF Control Module pins 7 & 8 will need to be removed from the connector and tied back.

Note: Pins 7& 8 provide a wheel speed input signal that is not utilized by the ULF Control Module and need to be disconnected from the control module.

5. Open the connector by pushing out on the lock tap(s) (1) and slide the terminal housing (2) out of the connector housing.

6. Locate pins 7 & 8 (2) and carefully remove them from the terminal housing (1).

7. Bend the wires for pin 7 & 8 back away from the connector
8. Wrap each terminal separately with electrical tape and tape them to the wiring harness.
9. Reassemble the connector.

10. Connect the 54-pin connector (2) and white FAKRA connector (1) to the ULF Control Module (F).

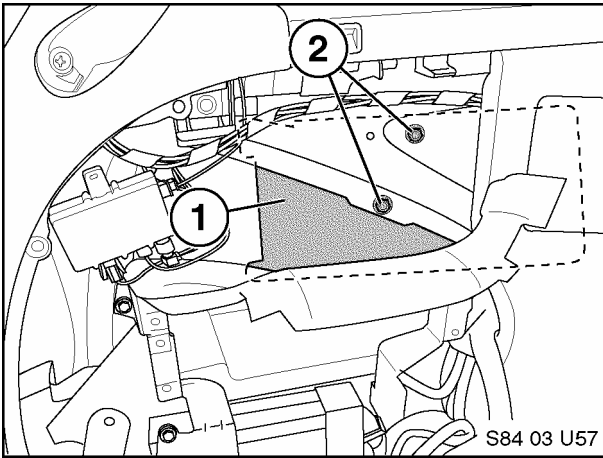

11. Insert the ULF Control Module and bracket (1) into the opening in the inner area of the rear quarter panel, and place the bracket against the inner portion of the support structure.

12. The three threaded lugs on the mounting bracket should be inserted through the three holes in the support structure (2).

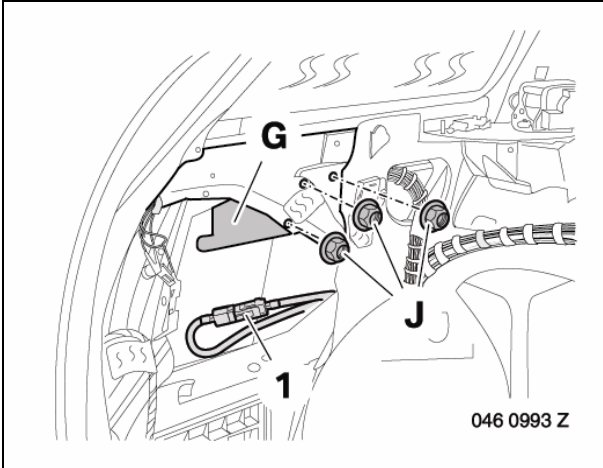

13. Secure the bracket (G) in place using three M5 hex nuts (J), P/N 63 21 1 371 401.

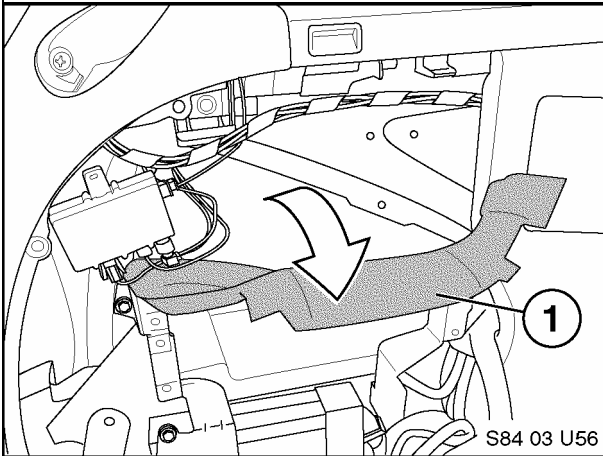

14. Reinstall the felt panel (1) and components removed previously.

### E46 Sedan with Carrier Rack

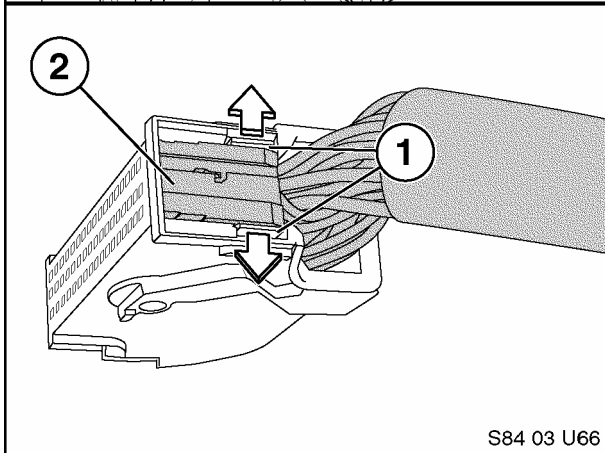
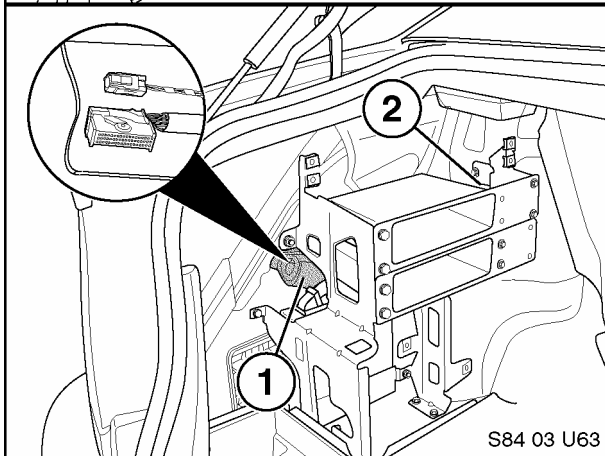
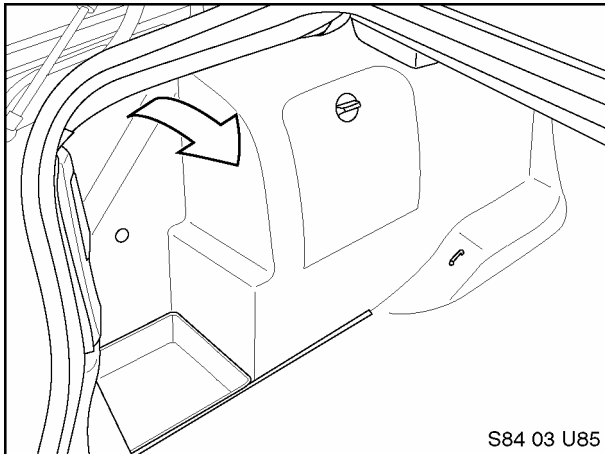

1. If the left rear of the trunk is as shown, then a component carrier rack is already installed and the following steps should be followed.
2. If the trunk is not as shown refer to the installation steps for no carrier rack installed, on page 12.
3. Remove the left rear trim panel.
4. Locate the black 54-pin connector and white FAKRA connector bundle (1), near the left rear wheel well housing.
5. Route the 54-pin connector and white FAKRA connector along the right side of the component carrier rack (2), making certain that the 54 pin connector and white FAKRA connector can be connected to the ULF Control Module as indicated in the following steps.
6. Prior to connecting the black 54-pin connector to the ULF control Module pins 7 & 8 will need to be removed from the connector and tied back. (Wires are only present on vehicles produced as of 8/02)  
 Note: Pins 7& 8 provide a wheel speed input signal that is not utilized by the ULF Control Module and need to be disconnected from the control module.
7. Open the connector by pushing out on the lock tap(s) (1) and slide the terminal housing (2) out of the connector housing.

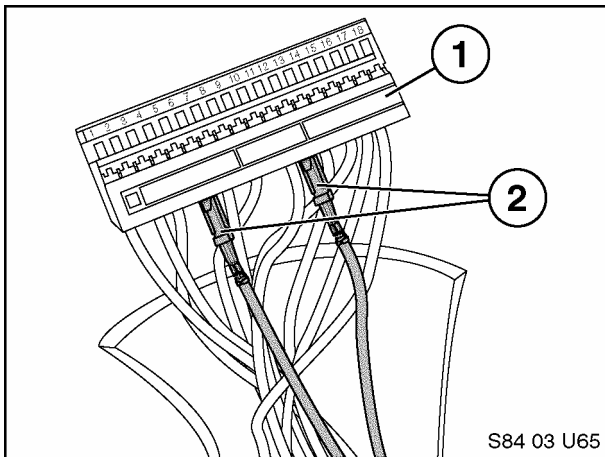

8. Locate pins 7 & 8 (2) and carefully remove them from the terminal housing (1).

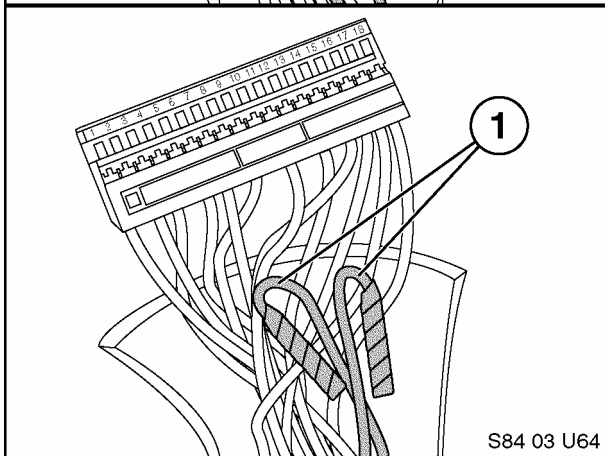

9. Bend the wires for pin 7 & 8 back away from the connector  
 10. Wrap each terminal separately with electrical tape and tape them to the wiring harness.  
 11. Reassemble the connector.

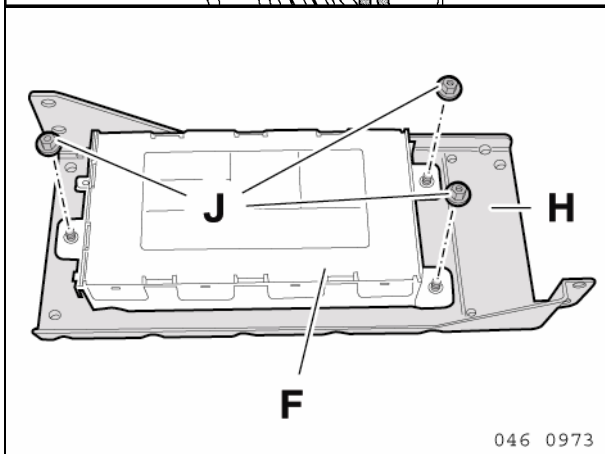

12. Attach the ULF Control Module (F) to the mounting bracket (H) P/N 84 13 6 924 553 using three M5 hex nuts (J) P/N 63 21 1 371 401.

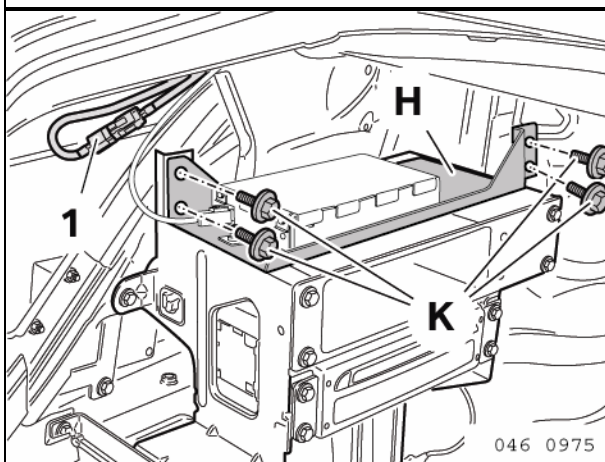

13. Install the ULF Control Module-mounting bracket (H) using four clip nuts P/N 61 13 1 372 033, which need to be placed onto the left and right carrier bracket in order to install the four M5 Hex bolts (K), P/N 07 11 9 902 932.

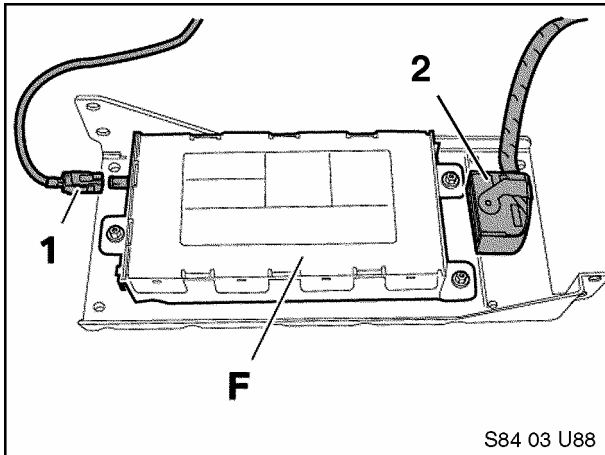

14. Connect the 54-pin connector (2) and white FAKRA connector (1) to the ULF Control Module (F) after the bracket is installed.

15. Reinstall the left rear trim panel.

### E46 Sedan With No Carrier Rack

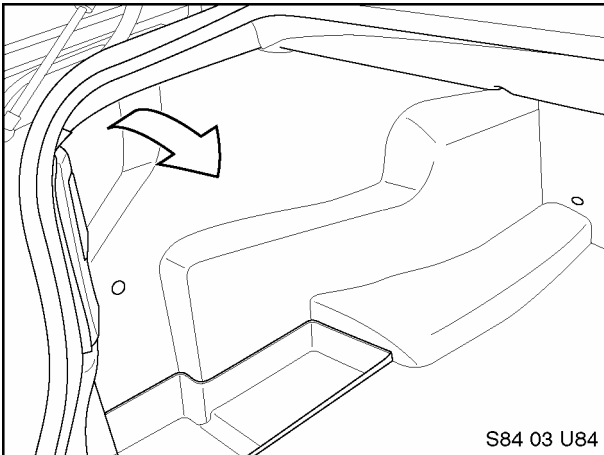

**IMPORTANT:** In the event a vehicle is not equipped with a carrier bracket the trunk will look as indicated in the illustration.

1. Remove left rear trim panel.

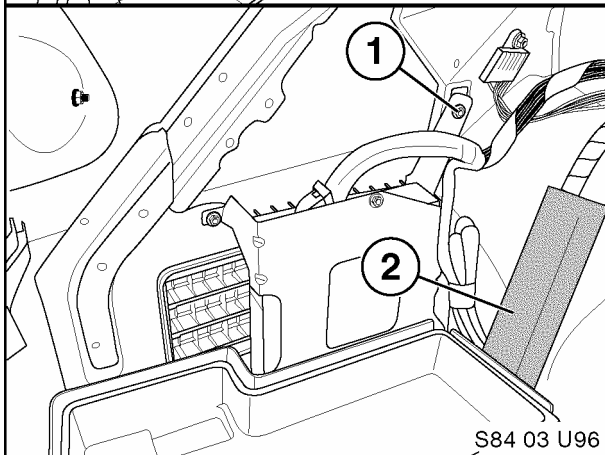

2. Remove the securing bolt (1) for the amplifier securing bracket and the clip-nut  
3. Locate the telephone connector bundle (2).

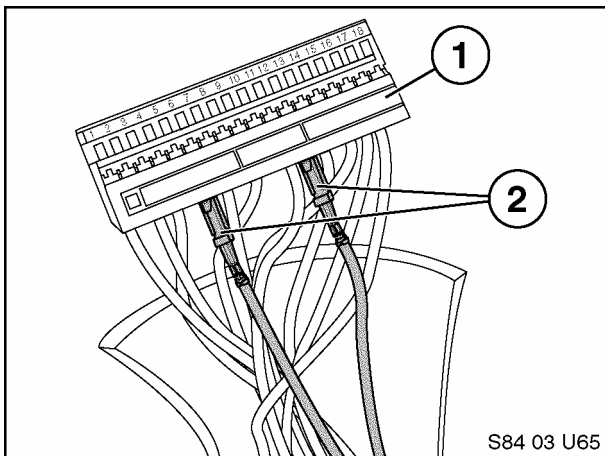
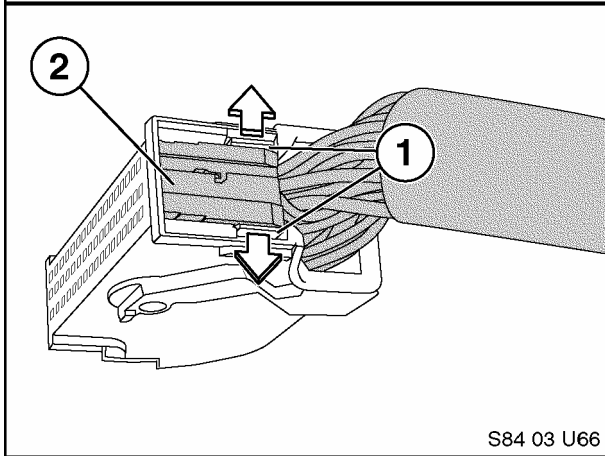
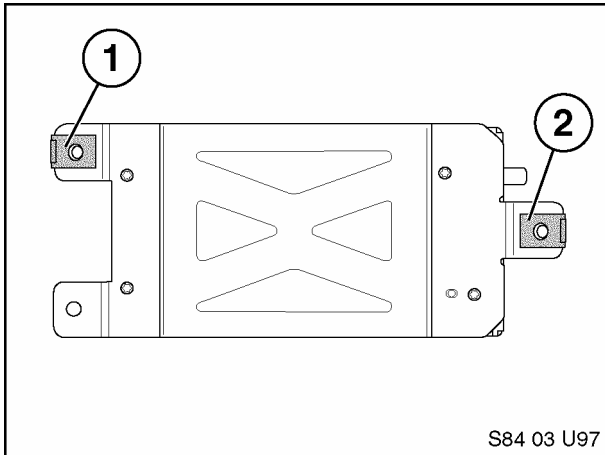

6. Attach the two clip nuts (1 & 2), P/N 61 13 1 372 033, to the ULF Control Module as shown.

7. **For E46 vehicles produced prior to 8/02 continue with step 14.**

8. **For E46 vehicle produced as of 8/02 only:** Prior to connecting the black 54-pin connector to the ULF control Module pins 7 & 8 will need to be removed from the connector and tied back (Pin 7 & 8 are only used on vehicles produced as of 8/02)

Note: Pins 7& 8 provide a wheel speed input signal that is not utilized by the ULF Control Module and will need to be disconnected from the control module.

9. Open the connector by pushing out on the lock tap(s) (1) and slide the terminal housing (2) out of the connector housing.

10. Locate pins 7 & 8 (2) and carefully remove them from the terminal housing (1).

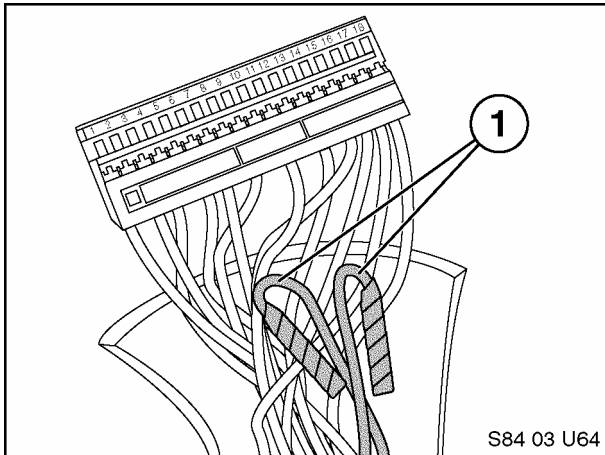

11. Bend the wires for pin 7 & 8 back away from the connector
12. Wrap each terminal separately with electrical tape and tape them to the wiring harness.
13. Reassemble the connector.

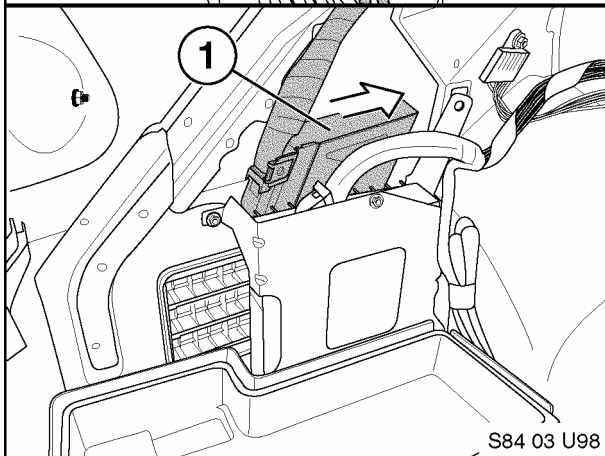

14. Locate the black 54-pin connector and white FAKRA connector.
15. Slide the ULF control module (1) into the open area behind the amplifier.

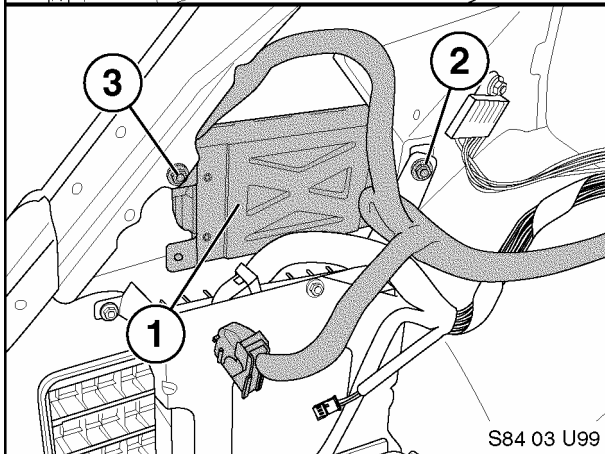

15. Secure the ULF Control Module (1) to the interior of the support structure using two M5 hex bolts (2 & 3), P/N 07 11 9 902 932.
16. Reinstall the trim panel

### C. Installation of Voice Input Jumper

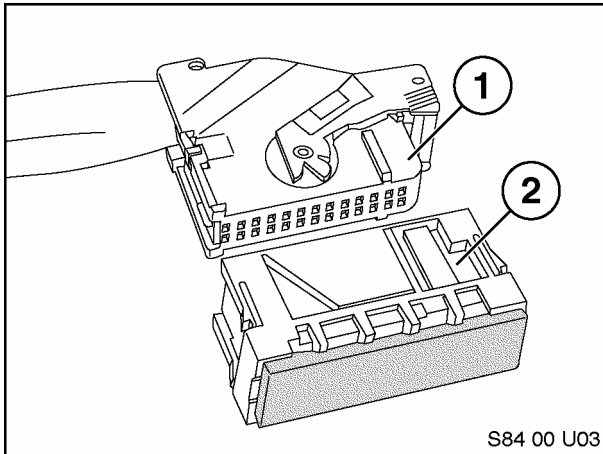

1. If a Voice Input Jumper Plug is not installed then a Jumper Plug, P/N 84 11 0 018 038, must be obtained and installed for the system to function correctly. The jumper plug should be installed onto a blue 26 pin connector that is located near the black 54 pin connector for the ULF module.

Note: The Jumper plug is not included in the kit as this plug may already be installed on some vehicles.

### D. Installation of Microphone

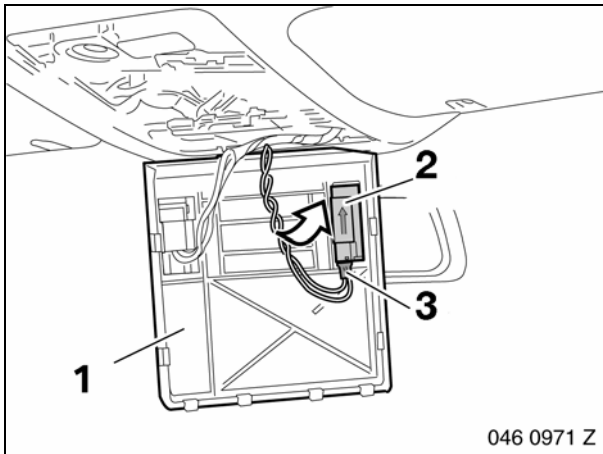

1. Carefully pull down the access panel (1).
2. Locate the black 3-pin connector X18507 that is taped to the harness.
3. Install microphone (E) P/N 84 31 8 380 319, with the arrow on the microphone pointing to the front of the vehicle, into the microphone fret and connect X4221 to the microphone.

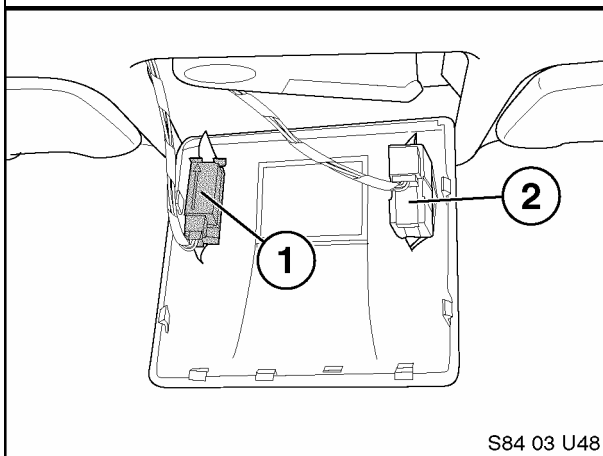

4. In the event of a customer complaint indicating that the outgoing audio from the vehicle sounds distant, the location of the microphone and sunroof switch can be reversed to place the microphone closer to the driver.

### Reconnect the Battery

### **Coding ULF Control Module to Vehicle**

After installing the ULF Kit, the vehicle should be re-coded with DIS/GT1 SW 33 or higher, using the “Retrofit” path to ensure that the system works properly with the systems currently installed in the vehicle. The recoding is done automatically when using the following “retrofit” procedure:

- Connect DISPlus or GT1 to vehicle (with SW 33 or higher installed)
- Turn on ignition
- Select “Coding ZCS”
- Series: “E46 Series”
- Path: “2 Retrofit”
- System: “ULF Universal charging and Handsfree facility”.
- Follow the on screen requests to activate the coding procedure.

### **E. Function test**

Upon completion of the recoding, verify that the BMW Universal Bluetooth™ Hands-Free System is working correctly by going through the following action steps. After completing each step ensure that the desired result is obtained:

<b>Action</b>	<b>Response</b>
Pair phone to vehicle (refer to section for pairing instructions).	Phone and or Radio/MID/Board Computer should display statement indicating Pairing succeeded
Turn on radio and initiate a call using voice recognition commands by depressing/holding the Voice recognition button on steering wheel until an audible beep is heard	Radio should mute and an audible beep is heard through vehicle speakers.
Say “Dial number”	System states “Please speak the number”
Say phone number to be dialed ex”1234567890”	System states “1234567890”
If number is correct say “Dial”	Call is placed and number being dialed is displayed on phone as well as on Radio/MID/Board Computer.

**F. Troubleshooting:**

<b>Situation</b>	<b>Correction</b>
No audio output through vehicle speakers	Check SES module jumper plug
Radio does not mute after placing a call	Check connections at rear of radio for Tel On and Tel Mute signal. Verify that connectors and pins are properly seated.
Audio quality in vehicle may not sound very good	<ul style="list-style-type: none"> <li>- Recode ULF Control Module.</li> <li>- NOTE: Audio quality in vehicle or at person being contacted, is dependent on the quality and signal strength of the wireless service provider in the area traveled.</li> </ul>
Customer complains that the person being contacted hears a “Buzzing” noise, at times during their conversation or on voice mail message that he/she has left.	Intermittently a “Buzzing” noise is noticeable to the person being called from the vehicle. The “Buzzing” noise is a result of the GSM signal being feedback through the microphone, this usually occurs if the GSM phone is located too close to the microphone. The customer should change the location of where the phone is placed/stored.
Driver is told that the person being contacted complains that there is an echo/reverberation in the audio; person can hear his/her voice back through the phone.	Audio volume in vehicle during a call may be a bit to loud, causing the other person to hear his/her voice coming back through the phone.
A second call is received while in a call, and call cannot be accepted using MFL controls.	Use handset to expect second call and place previous called on hold. Call waiting is functional only via the handset.
The radio audio does not come back immediately if the “other” person hangs up first.	It takes approximately 15 seconds for the ULF system to recognize that the call was terminated from outside the vehicle. If the call is terminated from outside the vehicle first, the driver can depress the button on the steering wheel to terminate the call from the vehicle and unmute the radio quicker.
Customer is not able to pair phone to system, not able to locate ULF passkey/password reference card.	<ul style="list-style-type: none"> <li>- The “Bluetooth™ Passkey” is identified on the label of the ULF Control Module located in the rear of the vehicle.</li> <li>- The “Bluetooth™ Passkey” for the installed control module can be obtained by connecting the DISPlus or GT1and accessing the diagnostics for the ULF system:               <ul style="list-style-type: none"> <li>- select “Diagnostic requests”</li> <li>- select “Bluetooth code”</li> </ul> </li> </ul>
Intermittently a popping noise is audible through the vehicles speaker and there is no Bluetooth™ wireless communication established between the ULF module and the phone.	<ul style="list-style-type: none"> <li>- Vehicle and /or ULF Control Module are not correctly coded.</li> <li>- Recode module and vehicle (refer to Coding ULF Control Module to Vehicle)</li> </ul>
E46 Only: After installation of ULF system the speedometer and odometer do not work.	Remove pin 7 & 8 from the 54-pin connector going to the ULF Control Module. Refer to the E46 installation instructions.

## G. Pairing Procedure:

The pairing procedure that must be initiated through the phone will differ corresponding to the different menu configurations of the various Bluetooth™ mobile phones on the market. The user's manual of the phone should always be referenced for specific steps on how to activate the Bluetooth™ feature and to pair/link devices.

The following steps are generalized steps that should help in activating the Bluetooth™ function of most phones:

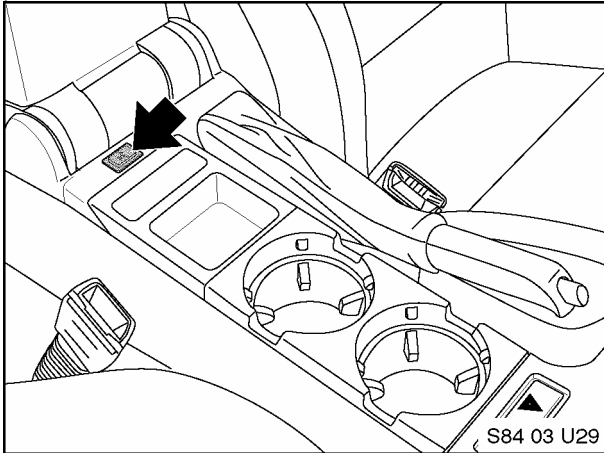

### IN VEHICLE:

1. Depress the pairing button for at least 1 second prior to switching on the ignition and continue to hold the button down for approximately 2-3 seconds after the ignition is turned on.
2. Release the button.

3. Shortly after releasing the button the Radio or Board Monitor display should look like one of the following:

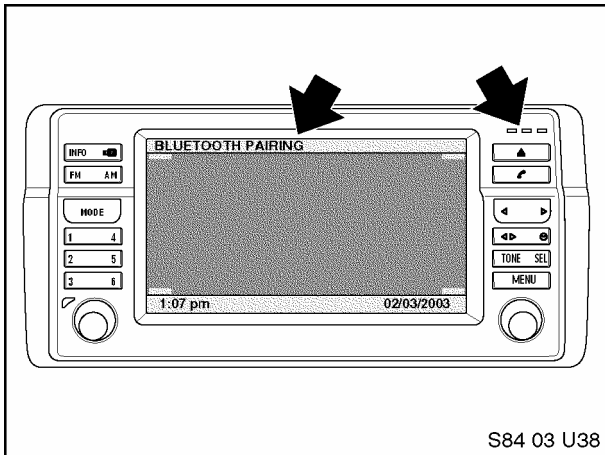

a. Board Monitor Display:

- "Bluetooth Pairing" displayed.
- Green, Yellow and Red LEDs on the right side of the unit are flashing which indicates that the ULF is searching for available Bluetooth™ devices.

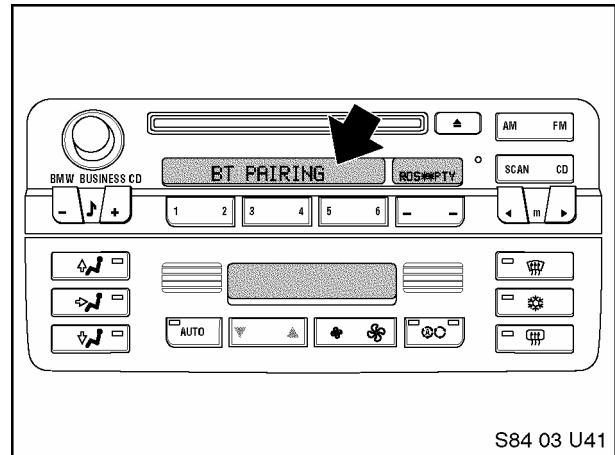

b. Radio Display:

- "BT Pairing" display which indicates that the ULF is searching for available Bluetooth™ devices.

4. Activate the search function of the phone as indicated below.

### ON PHONE:

1. Locate the connection/settings menu and select Bluetooth™.
2. Select the response that will activate the Bluetooth™ feature of the phone.
3. Next select a menu option that will allow you to "Discover" or "Search" for active Bluetooth™ devices.

4. If the phone identifies/finds a device select it and follow the indicated steps to complete the pairing process.
5. Once the phone is successfully paired to the device cycle the ignition switch off and back on and the devices should wirelessly connect within 30 seconds. When the connection is established the phone will display a connection symbol.

*The following steps are an example of the pairing procedure that must be initiated to pair the Sony Ericsson T68i phone to the ULF Control Module.*

1. Press the menu button.
2. Select "Connect".
3. Select option 3: "Bluetooth".
4. Select option 4: "Options".
5. Select option 1: "Operation mode" and set to "On" or "Automatic".
6. Go back one step by pressing the red phone button.
7. Select option 3: "Discover".
  - Mobile Phone display shows 'Searching'
8. Select "BMW ....." in upcoming list.
9. Select option 1: "Add to paired".
10. Enter password (= ULF passkey) located on ULF Control Module in the rear of the vehicle or on the Passkey Reference Card.
  - Mobile Phone display shows 'BMW ..... Pairing'
  - Mobile Phone display shows 'Pairing Successful'
  - Board Monitor display shows 'Pairing succeeded' for 3 seconds
11. Enter device name.
12. Mobile Phone display shows "Added to paired devices".
13. Quit menu by pressing the red phone/NO button for several seconds.

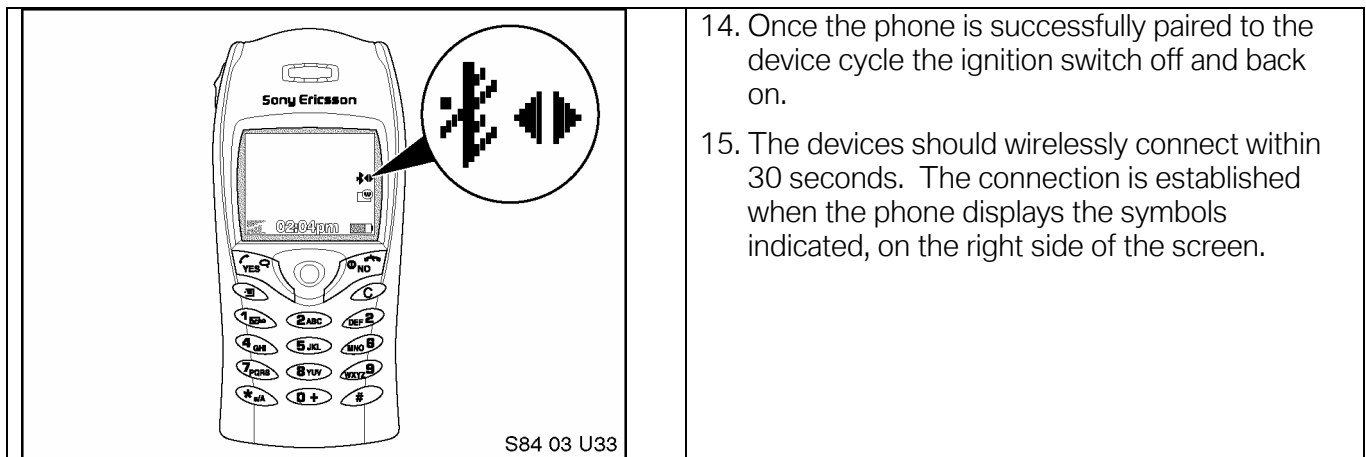

**Note:** Shortly after turning on the ignition and the Bluetooth™ connection is identified, the phone may display a message asking if the connection should be established/accepted. The connection authorization request will always occur unless the setting on the phone is modified to allow automatic connection every time, please refer to the user's manual of the phone to determine how to change this setting.

**COMPONENT LOCATION:**

**SPORT WAGON**

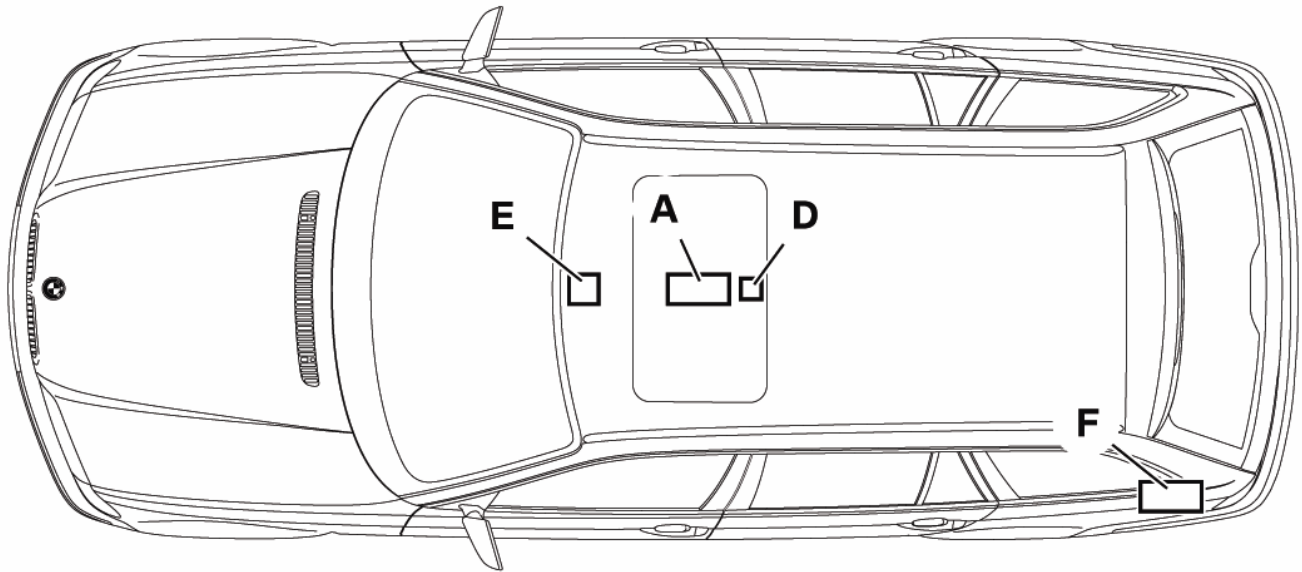

046 0980

**SEDAN**

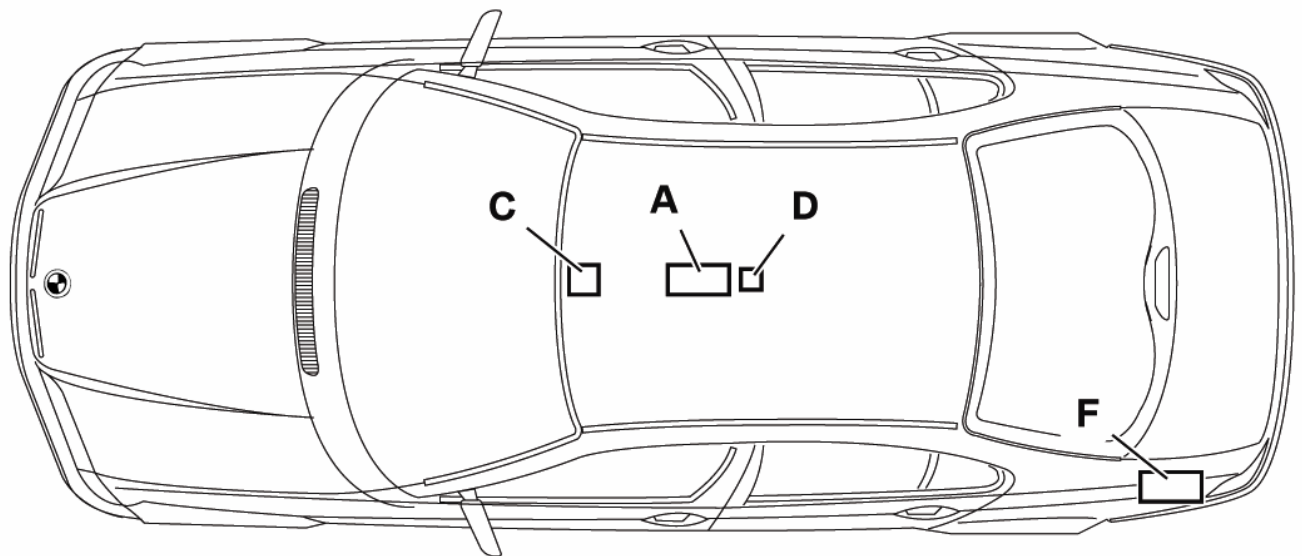

046 0961

A - Eject Box  
D - Bluetooth™ Antenna

C/E - Microphone  
F - ULF Control Module

# ULF Wiring Schematic for the E46 with Boardmonitor

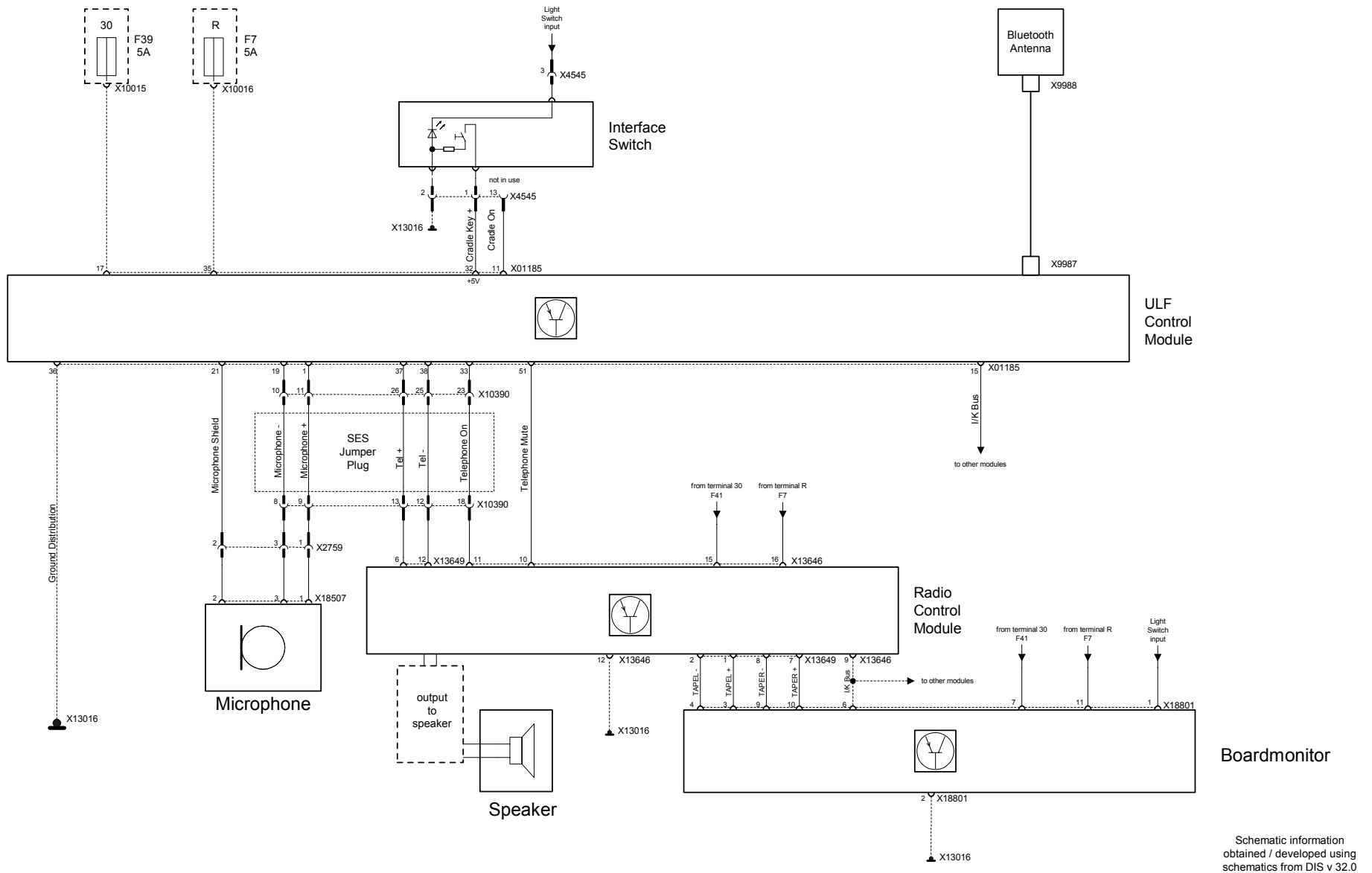

Schematic information obtained / developed using schematics from DIS v 32.0

# ULF Wiring Schematic for the E46 without Boardmonitor

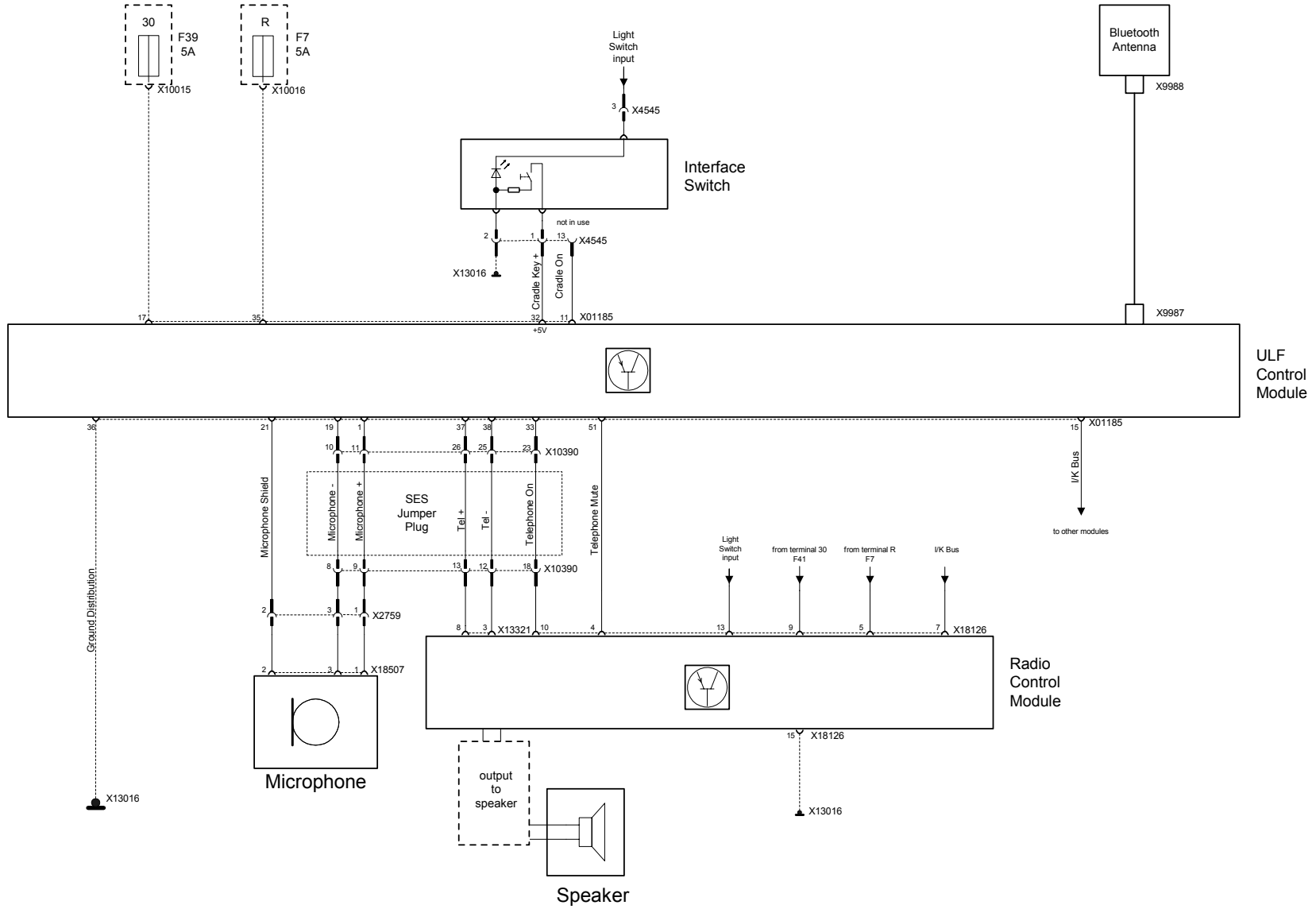

Schematic information obtained / developed using schematics from DIS v 32.0